



VacuStar WR 2500 – 3100

Liquid ring compressor vacuum-pump

CVS develops and manufactures compressor vacuum-pumps specifically designed for installation in vacuum trucks. The development is made in close collaboration with our customers. This guarantees the optimum product for your application.



The liquid ring compressor vacuum-pump

The series WR was developed especially for the high requirements on mounting in suction vehicles, municipal vacuum trucks and combination trucks (combined suction and water jetting).

Features

- » High quality liquid ring compressor vacuum-pumps from CVS for higher suction level and more suction power
- » Unique and robust design guarantee long lasting performance and high operating hours
- » Compact and light-weight liquid ring compressor vacuum-pumps for higher payload on the truck

Liquid ring compressor vacuum-pumps with system

The series WR consists of 3 sizes with a volume flow of up to 4065 m³/h / 2393 cfm.

Advantages

- » Swivel mounted pump between the mounting feet
- » Suction and pressure flange can be connected electively on shaft side or opposite
- » Mechanical seal
- » Low weight design by using aluminum
- » Connection flanges can be swiveled
- » Installation friendly design
- » Only one water drain





Dimensions

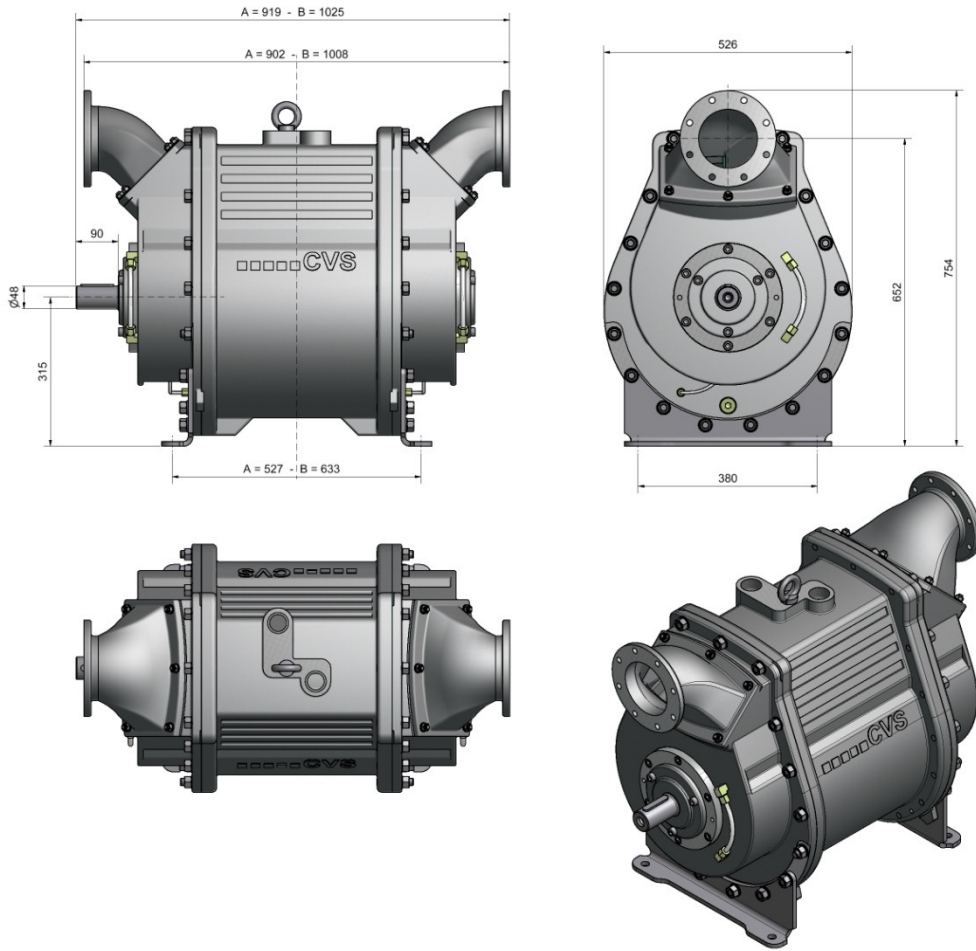

A = WR 2500
B = WR 3100

Technical data

		VacuStar WR 2500	VacuStar WR 3100
Max. volume flow	m³/h / cfm	2500 / 1470	3100 / 1825
Max. operating pressure	bar g / psig	1.5 / 21.3	1.5 / 21.3
Max. operating vacuum*	mbar / HG“	130 / 26	130 / 26
Speed range	1/min / rpm	800 - 1600	800 - 1600
Max. power requirement at 0.5 bar g / 7.25 psig	kW / hp	77.0 / 105	94.0 / 128
Sound pressure level in 7 m distance at 400 mbar / 18 HG“	dB(A)	70	72
Weight	kg / lb	175 / 385	192 / 422

*Depending on cooling water temperature

Technical subject to alteration